

CHANGES				
SYM	BY	REVISION	DATE	
-	PAG	CHANGED TO ENGLISH	03/10/08	

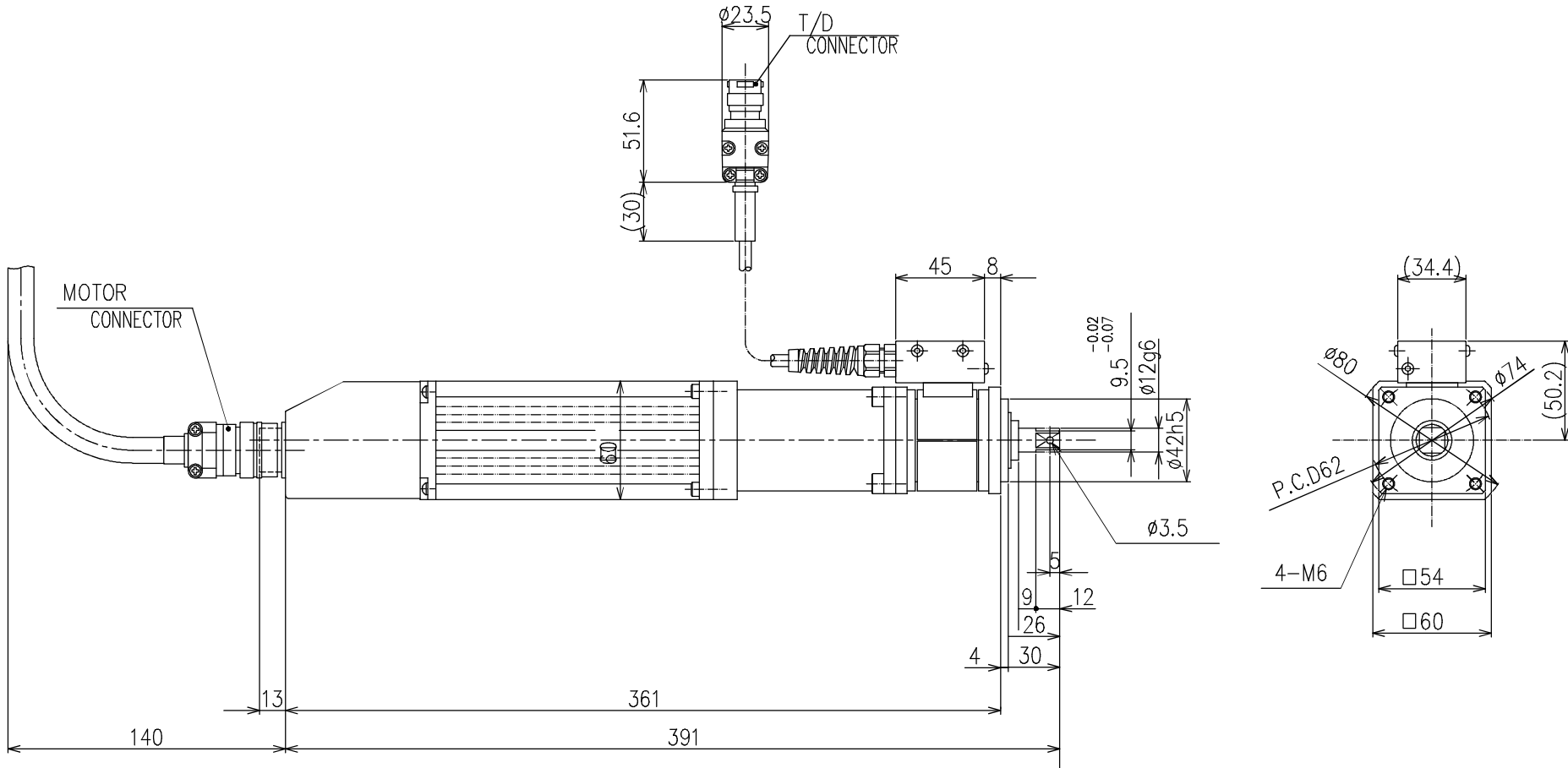

1. FULL SCALE TORQUE      2 kgf-m (19.6N-m)
2. MAX FREE SPEED        790R.P.M
3. WEIGHT                      kgf

TOLERANCE UNLESS OTHERWISE SPECIFIED

INCH	METRIC
.XX=±.01	.X=±.25
.XXX=±.005	.XX=±.127
.XXXX=±.0005	.XXX=±.0127
ANGLE=±.5°	ANGLE=±.5°

1. DO NOT SCALE DRAWING.
2. BREAK ALL SHARP CORNERS & EDGES EXCEPT AS NOTED.
3. USE HI-COLLAR LOCKWASHERS UNDER ALL SDC. HD. SCREWS.
4. APPLY LOC-TITE TO ALL SCREWS.

**NOTICE OF PROPRIETARY RIGHTS**  
The design concepts and engineering detail embodied in this drawing are the property of FEC INC. and one to be maintained in strict confidence; no element or detail of this drawing is to be disclosed nor used without the express written permission of FEC INC.

AMT	SYN	SHI	NAME	PART #	MFG.

DES BY DDK	DET BY DDK	TITLE TOOL OUTLINE
CHK BY SAFETY DK		
DATE 03/19/08	SCALE FULL	METRIC
SHEET -	SHEETS -	DRAWING NO. NFT-201RM3A-S